

## Longitudinal Installation ...

\* Supplied with spar hardware

\*\* Supplied with Encoder hardware

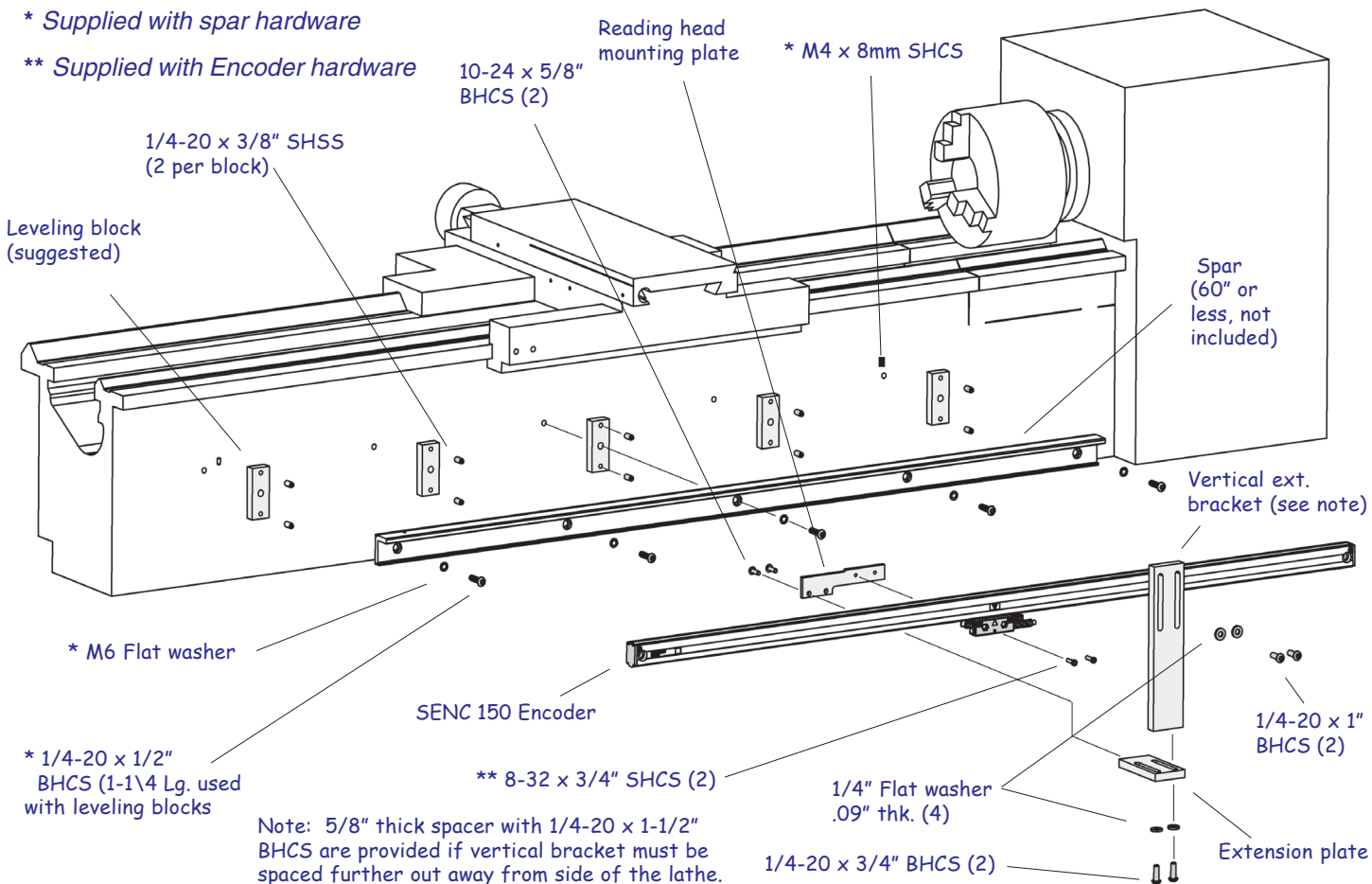

## Mounting Information...

These are application instructions for mounting the Longitudinal "Z" axis SENC 150 encoder.

### Before proceeding:

- Please read the instructions completely.
- Mount Z axis prior to installing the cross feed.
- Keep the reading head centered during installation.
- Clean the mounting surfaces.
- Save the alignment brackets with the Encoder Reference Manual after installation is completed.

## First Steps ...

### Machine

- ✓ Move the cross feed to its center of travel.
- ✓ Mark the location so that it can be re-centered easily.

### Encoder

- ✓ Unpack encoder in a safe, convenient location.
- ✓ Do not remove the reading head alignment brackets until instructed.

## Center reading head ...

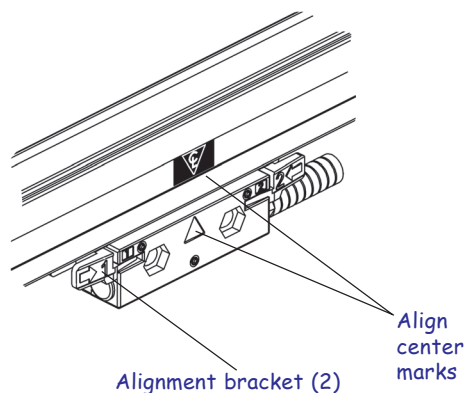

- Slide the reading head and brackets along the scale case until the center marks on the scale case and reading head are aligned.

### Encoder orientation ...

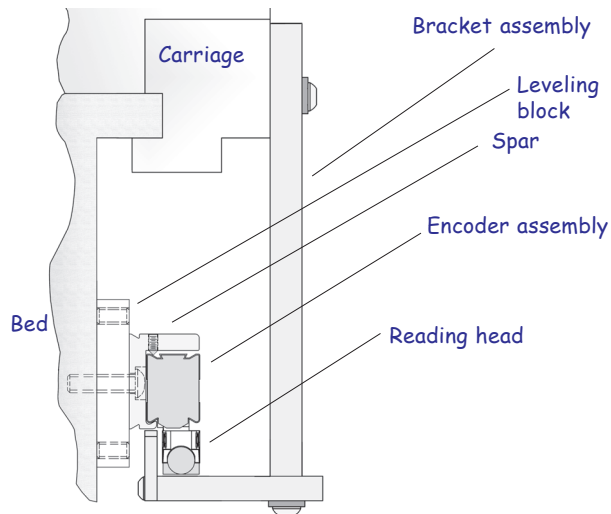

- These instructions will guide you through installing the encoder as shown in this view.

### Encoder/Spar assembly ... (If used)

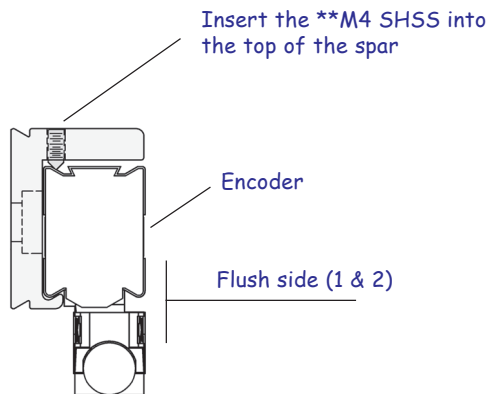

- Insert the encoder into the spar as shown, and center from end to end. Tighten the center set screw only.

### Cable exit ...

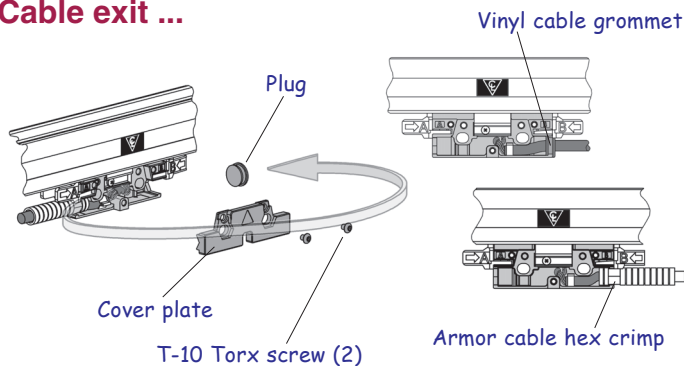

- Determine the cable exit direction before installing the encoder.
- To change the cable exit direction, remove the cover plate and rotate the cable 180°.

### Bracket assembly ...

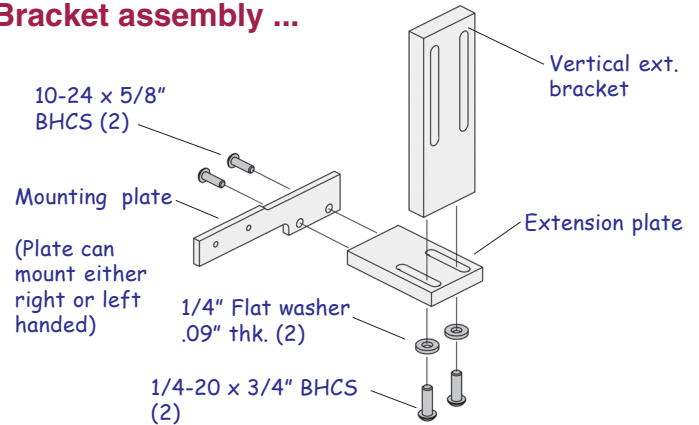

- Assemble the brackets, fully extending the extension plate.

### Bracket attachment ...

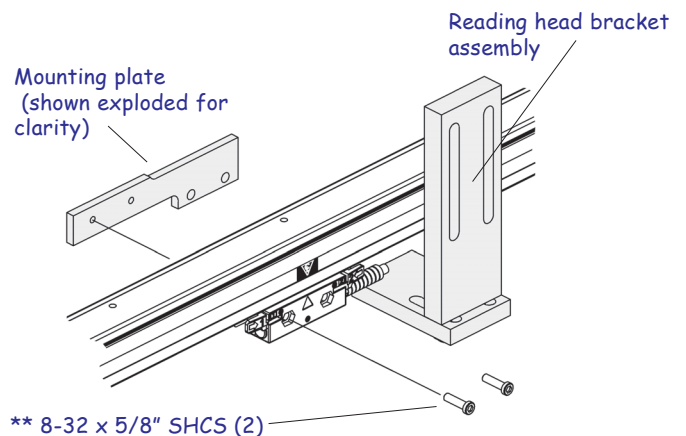

- Temporarily attach the bracket assembly to the reading head for locating purposes.

### Spar / encoder installation ...

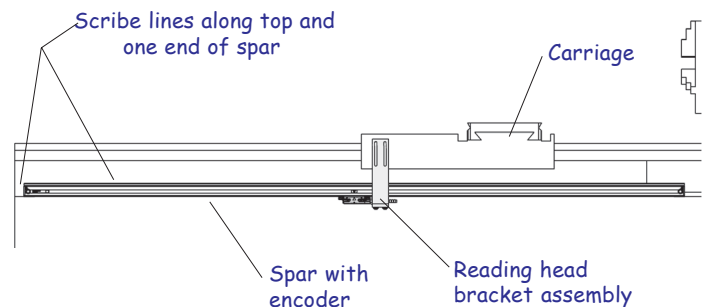

- With the carriage at its center of travel, position the spar / or encoder to the side of the bed, and the bracket assembly to the carriage.
- Locate the assembly so that a suitable mounting position is provided for both the encoder (or w/spar) to the bed, and the bracket assembly to the carriage.
- With the spar / or encoder parallel to the bed ways, scribe location reference lines on the bed. Remove the assembly.

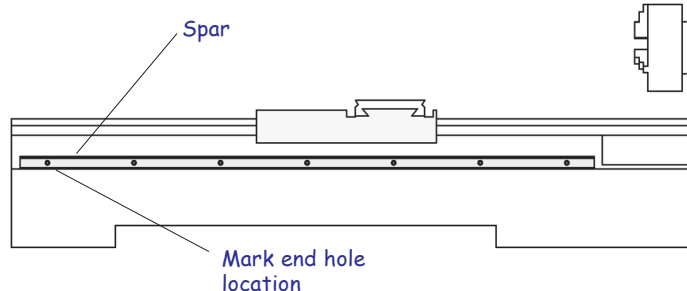

- Remove the bracket assembly from the reading head, (and the encoder from the spar).
- Position the spar / or encoder to the scribed lines and mark one end mounting hole location to the bed.
- Drill and tap location for a 1/4-20 x 1/2" deep.

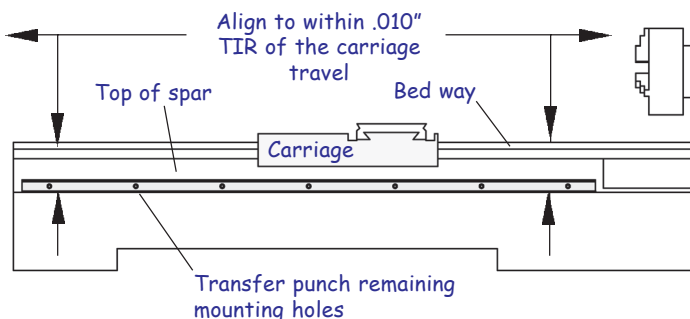

- Fasten the spar / or encoder to the bed at one end.
- Align the top of the spar / or encoder to the carriage travel to within .010" TIR.
- Transfer punch the remaining mounting hole(s).
- Remove spar / or encoder, drill and tap locations for a 1/4-20 x 1/2" deep.

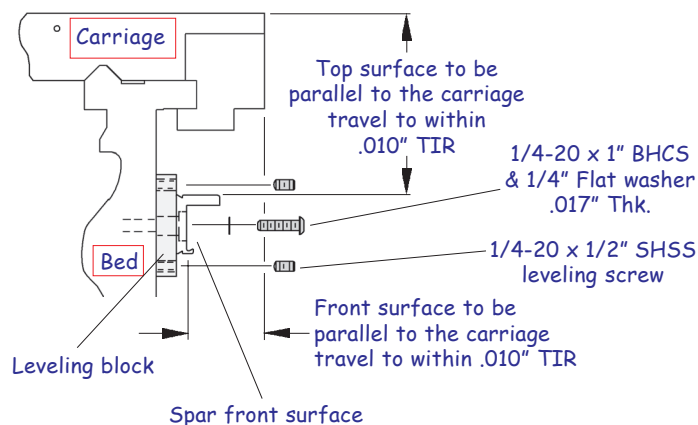

- Attach the spar/encoder with the leveling blocks (if used) to the bed. (Insert leveling screws in blocks).
- Align the front surface of the spar / or encoder to within .010" TIR of the carriage travel.
- Align the top surface to within .010" TIR of the carriage travel. Secure in place maintaining alignments.

### Encoder installation ... (If spar is used)

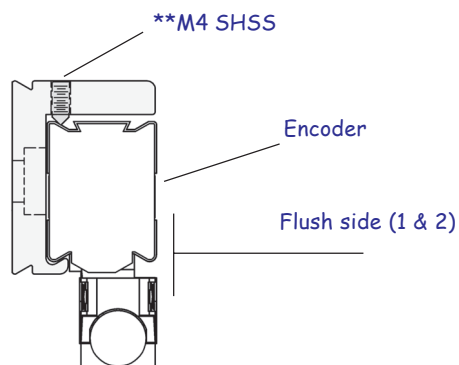

- Insert the encoder into the spar as done previously.
- Tighten the spar set screws starting from the center, working out towards the ends.

### Reading head and bracket installation ...

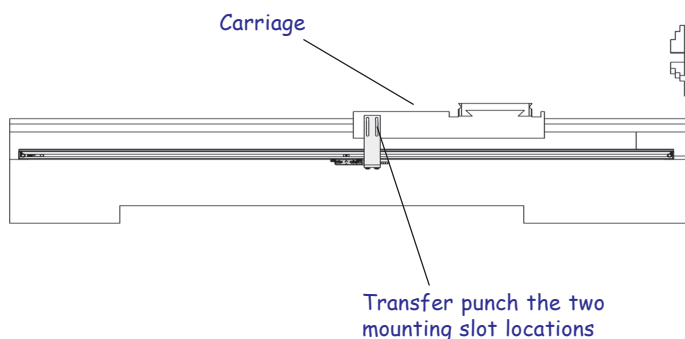

- Move the carriage to its center of travel. Attach the bracket assembly to the reading head.
- Position the assembly to the carriage, and transfer punch the two mounting slot locations.
- Remove the assembly, drill and tap the locations for 1/4-20 x 1/2" deep.

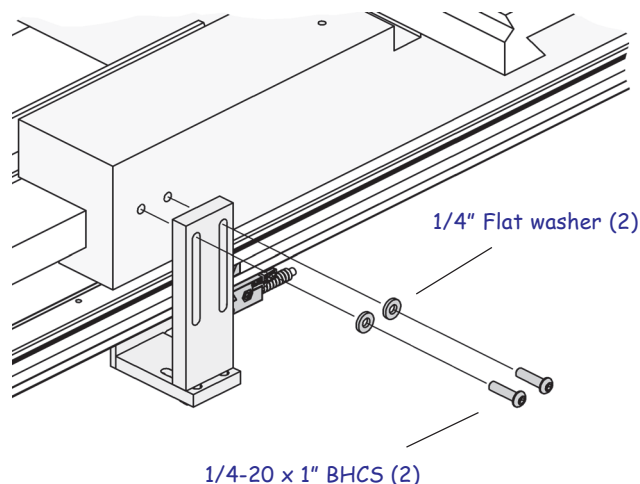

- Attach the bracket assembly to the carriage.

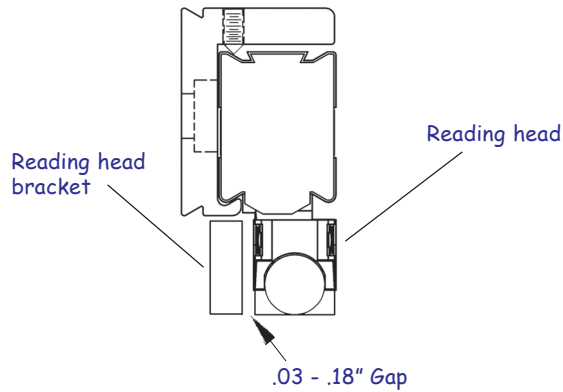

- Adjust the extension plate so that a .03" - .18" gap is between the reading head and bracket.
- Align the bracket and head mounting holes.
- Secure bracket assembly in place.

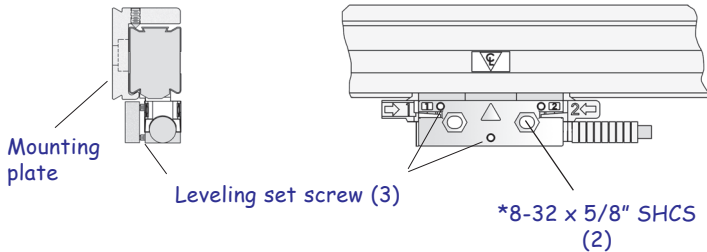

- Set each leveling screw by placing a .001 - .003" feeler gage between the screw and reading head mounting plate.
- Adjust each screw until a slight drag is felt on the feeler gage.
- **Evenly tighten** the two \*\*8-32 SHCS.

## Encoder button up ...

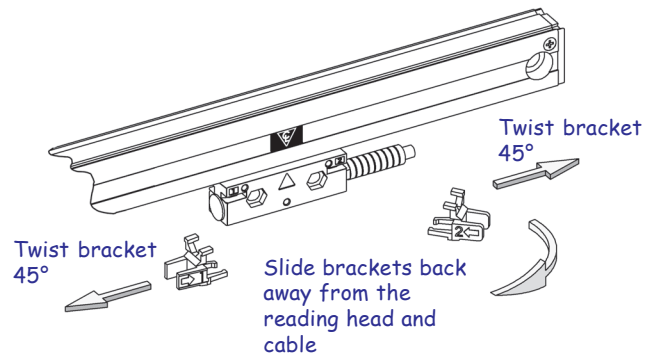

- Use allen wrench from set screw adjustment to slide alignment brackets away from the reading head.
- Remove alignment brackets and save for possible future use.
- Move the axis through its full travel. Confirm that the assembly does not interfere with the machine movement.

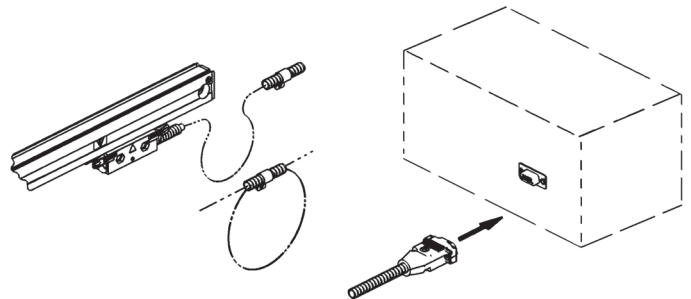

- With the longitudinal axis installation complete, route the cables providing sufficient slack loops for machine movement to the readout.
- Secure cables by fastening with clips or ties.
- Attach the encoder connectors to the readout.
- Complete the installation by following the steps in "Checking Your Installation" section in the encoder "Reference Manual".